

XD40TM and XD50TM Hose Reels

3A2990L

EN

Used in applications requiring long range dispense, transfer or evacuation of motor oils, diesel fuels*, lubricants, water, waste oil and air.

Not for use with gasoline or other flammable fluid. Not approved for use in hazardous or explosive atmosphere locations. For professional use only.

**less than 20% biofuel content*

Models

(see page 3 for addition model information)

Spring Hose Reels

XD40 - Floor, Truck-bed or Overhead Mounted

XD50 - Floor or Truck-bed Mounted



Important Safety Instructions

Read all warnings and instructions in this manual. Save these instructions.

Related Manual:

332203 - Repair Instructions

XD40

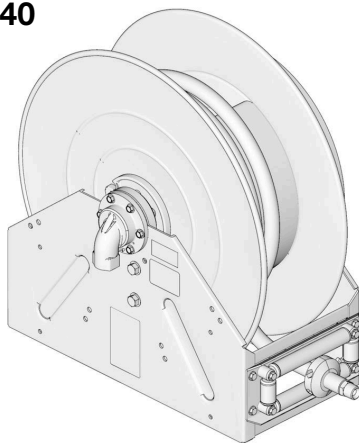

XD50

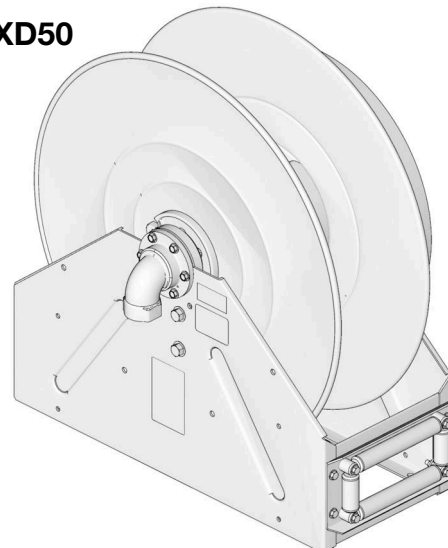

Table of Contents

Models	3
Warnings	8
Installation	10
Installation Notes	10
Grounding	10
Typical Layout	11
Pressure Relief Procedure	12
Hose Installation	12
Adjusting Spring Tension	15
Removing Spring Tension	17
Inlet Orientation	18
Mounting Options	20
Operation	24
Troubleshooting	25
XD40/XD50 Parts Drawing	27
XD40/XD50 Parts List	28
Related Kits	30
Technical Data	31
Dimensions	32
Table 1: Spring Tension Pre-turns	34
Air / Water / Antifreeze Models	34
Oil Models	34
Waste Oil Evacuation Models	34
Fuel Models	34
Graco 7-Year Hose Reel Warranty	36
Graco Information	36

Models

Understanding the Bare Reel Model Number

Bare reels are assigned a model number. This number identifies the frame size, port size, spring and pressure associated with that reel. For example an XD4010DLP model is an XD Model hose reel, size 40 frame, 1 inch port, D spring, low pressure.

- XD Frame Size: 40 or 50
- Port Size: 10 = 1 inch / 15 = 1.5 inch
- Spring Designation: A, B, C or D
- Pressure: LP - Low Pressure applications such as Air/Water, Fuel, and Waste Oil Evacuation typically under 300 psi (2.1 MPa, 21 bar) / MP - Medium Pressure applications such as Oil Dispense typically under 2000 psi (13.8 MPa, 138 bar)
- Inlet Seal Material - F - Fluorocarbon/FKM for general reels / N - Nitrile/Buna-n for anti-freeze

XD40 Bare Reels

Bare Reel Model	NPT Models	BSPP Models	BSPT Models	Color	Spring	Maximum Working Pressure		
						PSI	MPa	bar
XD4010DLPF	24P313	24P364	24P407	Blue	D	600	4.1	41
XD4010DLPF	24P315	24P366	24P408	Yellow	D	600	4.1	41
XD4010DLPF	24P316	24P367	24P409	White	D	600	4.1	41
XD4010CLPF	24P317	24P368	24P410	Blue	C	600	4.1	41
XD4010CLPF	24P318	24P369	24P411	Yellow	C	600	4.1	41
XD4010CLPF	24P319	24P370	24P412	White	C	600	4.1	41
XD4010CMPF	24P320	24P371	24P413	Blue	C	2000	13.8	138
XD4010CMPF	24P322	24P372	24P414	Yellow	C	2000	13.8	138
XD4010CMPF	24P323	24P373	24P415	White	C	2000	13.8	138
XD4010BMPF	24R854	24R864	24R867	Blue	B	2000	13.8	138
XD4010BMPF	24R855	24R865	24R868	Yellow	B	2000	13.8	138
XD4010BMPF	24R856	24R866	24R869	White	B	2000	13.8	138
XD4010AMPF	24P324	24P374	24P416	Blue	A	2000	13.8	138
XD4010AMPF	24P325	24P375	24P417	Yellow	A	2000	13.8	138
XD4010AMPF	24P326	24P376	24P418	White	A	2000	13.8	138
XD4010DLPN	26A140	NA	NA	Blue	D	600	4.1	41
XD4010DLPN	26A141	NA	NA	Yellow	D	600	4.1	41
XD4010DLPN	26A142	NA	NA	White	D	600	4.1	41

XD40 NPT, Reel with Hose - Air/Water

Bare Reel Model	Model	Color	Spring	Maximum Working Pressure			Hose Size
				PSI	MPa	bar	
XD4010DLPF	24P327	Blue	D	300	2.1	21	1/2 inch x 100 ft.
XD4010DLPF	24P328	Yellow	D	300	2.1	21	1/2 inch x 100 ft.
XD4010DLPF	24P329	White	D	300	2.1	21	1/2 inch x 100 ft.
XD4010DLPF	24P330	Blue	D	300	2.1	21	3/4 inch x 75 ft.
XD4010DLPF	24P331	Yellow	D	300	2.1	21	3/4 inch x 75 ft.
XD4010DLPF	24P332	White	D	300	2.1	21	3/4 inch x 75 ft.
XD4010CLPF	24P333	Blue	C	300	2.1	21	3/4 inch x 100 ft.
XD4010CLPF	24P334	Yellow	C	300	2.1	21	3/4 inch x 100 ft.
XD4010CLPF	24P335	White	C	300	2.1	21	3/4 inch x 100 ft.
XD4010DLPF	24P336	Blue	D	300	2.1	21	1 inch x 50 ft.
XD4010DLPF	24P337	Yellow	D	300	2.1	21	1 inch x 50 ft.
XD4010DLPF	24P338	White	D	300	2.1	21	1 inch x 50 ft.

XD40 NPT, Reel with Hose - Oil

Bare Reel Model	Model	Color	Spring	Maximum Working Pressure			Hose Size	Truck Mount Only
				PSI	MPa	bar		
XD4010AMPF	24P339	Blue	A	2000	13.8	138	1/2 inch x 100 ft.	
XD4010AMPF	24P340	Yellow	A	2000	13.8	138	1/2 inch x 100 ft.	
XD4010AMPF	24P341	White	A	2000	13.8	138	1/2 inch x 100 ft.	
XD4010CMPF	24P342	Blue	C	1530	10.5	105	3/4 inch x 75 ft.	X
XD4010CMPF	24P343	Yellow	C	1530	10.5	105	3/4 inch x 75 ft.	X
XD4010CMPF	24P344	White	C	1530	10.5	105	3/4 inch x 75 ft.	X
XD4010BMPF	24R857	Blue	B	1530	10.5	105	3/4 inch x 75 ft.	
XD4010BMPF	24R859	Yellow	B	1530	10.5	105	3/4 inch x 75 ft.	
XD4010BMPF	24R860	White	B	1530	10.5	105	3/4 inch x 75 ft.	
XD4010AMPF	24P345	Blue	A	1530	10.5	105	3/4 inch x 100 ft.	
XD4010AMPF	24P346	Yellow	A	1530	10.5	105	3/4 inch x 100 ft.	
XD4010AMPF	24P347	White	A	1530	10.5	105	3/4 inch x 100 ft.	
XD4010CMPF	24P348	Blue	C	1275	8.79	88	1 inch x 50 ft.	X
XD4010CMPF	24P349	Yellow	C	1275	8.79	88	1 inch x 50 ft.	X
XD4010CMPF	24P350	White	C	1275	8.79	88	1 inch x 50 ft.	X
XD4010BMPF	24R861	Blue	B	1275	8.79	88	1 inch x 50 ft.	
XD4010BMPF	24R862	Yellow	B	1275	8.79	88	1 inch x 50 ft.	
XD4010BMPF	24R863	White	B	1275	8.79	88	1 inch x 50 ft.	

XD40 NPT, Reel with Hose - Waste Oil Evacuation

Bare Reel Model	Model	Color	Spring	Maximum Working Pressure			Hose Size
				PSI	MPa	bar	
XD4010CLPF	24P351	Blue	C	250	1.7	17	1 inch x 50 ft.
XD4010CLPF	24P352	Yellow	C	250	1.7	17	1 inch x 50 ft.
XD4010CLPF	24P353	White	C	250	1.7	17	1 inch x 50 ft.

XD40 NPT, Reel with Hose - Diesel Fuel

Bare Reel Model	Model	Color	Spring	Maximum Working Pressure			Hose Size
				PSI	MPa	bar	
XD4010CLPF	24P354	Blue	C	250	1.7	17	1 inch x 50 ft.
XD4010CLPF	24P355	Yellow	C	250	1.7	17	1 inch x 50 ft.
XD4010CLPF	24P356	White	C	250	1.7	17	1 inch x 50 ft.

XD40 NPT, Reel with Hose - Antifreeze

Bare Reel Model	Model	Color	Spring	Maximum Working Pressure			Hose Size
				PSI	MPa	bar	
XD4010CLPN	24P984	Blue	C	300	2.1	21	3/4 inch x 100 ft.
XD4010CLPN	24P985	Yellow	C	300	2.1	21	3/4 inch x 100 ft.
XD4010CLPN	24P986	White	C	300	2.1	21	3/4 inch x 100 ft.

XD50 Bare Reels

Bare Reel Model	NPT Models	BSPP Models	BSPT Models	Color	Spring	Porting Size (Inches)	Maximum Working Pressure		
							PSI	MPa	bar
XD5010ALPF	24P455	24P500	24P549	Blue	A	1	600	4.1	41
XD5010ALPF	24P456	24P503	24P550	Yellow	A	1	600	4.1	41
XD5010ALPF	24P457	24P504	24P551	White	A	1	600	4.1	41
XD5015BLPF	24P461	24P508	24P555	Blue	B	1.5	600	4.1	41
XD5015BLPF	24P462	24P509	24P556	Yellow	B	1.5	600	4.1	41
XD5015BLPF	24P463	24P510	24P558	White	B	1.5	600	4.1	41
XD5010BLPF	24P464	24P511	24P559	Blue	B	1	600	4.1	41
XD5010BLPF	24P465	24P512	24P560	Yellow	B	1	600	4.1	41
XD5010BLPF	24P466	24P513	24P561	White	B	1	600	4.1	41
XD5015ALPF	24P467	24P514	24P563	Blue	A	1.5	600	4.1	41
XD5015ALPF	24P468	24P515	24P564	Yellow	A	1.5	600	4.1	41
XD5015ALPF	24P469	24P516	24P565	White	A	1.5	600	4.1	41
XD5010AMPF	24P458	24P505	24P552	Blue	A	1	2000	13.8	138
XD5010AMPF	24P459	24P506	24P553	Yellow	A	1	2000	13.8	138
XD5010AMPF	24P460	24P507	24P554	White	A	1	2000	13.8	138
XD5010ALPN	26A143	NA	NA	Blue	A	1	600	4.1	41
XD5010ALPN	26A144	NA	NA	Yellow	A	1	600	4.1	41
XD5010ALPN	26A145	NA	NA	White	A	1	600	4.1	41

XD50 NPT, Reel with Hose - Air/Water

Bare Reel Model	Model	Color	Spring	Maximum Working Pressure			Hose Size
				PSI	MPa	bar	
XD5010ALPF	24P470	Blue	A	300	2.1	21	1 inch x 75 ft.
XD5010ALPF	24P471	Yellow	A	300	2.1	21	1 inch x 75 ft.
XD5010ALPF	24P472	White	A	300	2.1	21	1 inch x 75 ft.
XD5010ALPF	24P473	Blue	A	300	2.1	21	1 inch x 100 ft.
XD5010ALPF	24P474	Yellow	A	300	2.1	21	1 inch x 100 ft.
XD5010ALPF	24P475	White	A	300	2.1	21	1 inch x 100 ft.

XD50 NPT, Reel with Hose - Oil

Bare Reel Model	Model	Color	Spring	Maximum Working Pressure			Hose Size
				PSI	MPa	bar	
XD5010AMPF	24P476	Blue	A	1275	8.79	88	1 inch x 75 ft.
XD5010AMPF	24P477	Yellow	A	1275	8.79	88	1 inch x 75 ft.
XD5010AMPF	24P478	White	A	1275	8.79	88	1 inch x 75 ft.

XD50 NPT, Reel with Hose - Waste Oil Evacuation

Bare Reel Model	Model	Color	Spring	Maximum Working Pressure			Hose Size
				PSI	MPa	bar	
XD5015BLPF	24P479	Blue	B	200	1.4	14	1.25 inch x 35 ft.
XD5015BLPF	24P480	Yellow	B	200	1.4	14	1.25 inch x 35 ft.
XD5015BLPF	24P481	White	B	200	1.4	14	1.25 inch x 35 ft.
XD5015BLPF	24P482	Blue	B	200	1.4	14	1.25 inch x 50 ft.
XD5015BLPF	24P483	Yellow	B	200	1.4	14	1.25 inch x 50 ft.
XD5015BLPF	24P484	White	B	200	1.4	14	1.25 inch x 50 ft.

XD50 NPT, Reel with Hose - Diesel Fuel

Bare Reel Model	Model	Color	Spring	Maximum Working Pressure			Hose Size
				PSI	MPa	bar	
XD5010BLPF	24P485	Blue	B	250	1.7	17	1 inch x 75 ft.
XD5010BLPF	24P486	Yellow	B	250	1.7	17	1 inch x 75 ft.
XD5010BLPF	24P487	White	B	250	1.7	17	1 inch x 75 ft.
XD5010ALPF	24P488	Blue	A	250	1.7	17	1 inch x 100 ft.
XD5010ALPF	24P489	Yellow	A	250	1.7	17	1 inch x 100 ft.
XD5010ALPF	24P490	White	A	250	1.7	17	1 inch x 100 ft.
XD5015BLPF	24P491	Blue	B	250	1.7	17	1.25 inch x 35 ft.
XD5015BLPF	24P492	Yellow	B	250	1.7	17	1.25 inch x 35 ft.
XD5015BLPF	24P493	White	B	250	1.7	17	1.25 inch x 35 ft.
XD5015BLPF	24P494	Blue	B	250	1.7	17	1.25 inch x 50 ft.
XD5015BLPF	24P495	Yellow	B	250	1.7	17	1.25 inch x 50 ft.
XD5015BLPF	24P496	White	B	250	1.7	17	1.25 inch x 50 ft.
XD5015ALPF	24P497	Blue	A	150	1.0	10	1.5 inch x 50 ft.
XD5015ALPF	24P498	Yellow	A	150	1.0	10	1.5 inch x 50 ft.
XD5015ALPF	24P499	White	A	150	1.0	10	1.5 inch x 50 ft.



XD50 NPT, Reel with Hose - Antifreeze

Bare Reel Model	Model	Color	Spring	Maximum Working Pressure			Hose Size
				PSI	MPa	bar	
XD5010ALPN	24P987	Blue	A	300	2.1	21	1 inch x 100 ft.
XD5010ALPN	24P988	Yellow	A	300	2.1	21	1 inch x 100 ft.
XD5010ALPN	24P989	White	A	300	2.1	21	1 inch x 100 ft.





Warnings

The following warnings are for the setup, use, grounding, maintenance, and repair of this equipment. The exclamation point symbol alerts you to a general warning and the hazard symbols refer to procedure-specific risks. When these symbols appear in the body of this manual or on warning labels, refer back to these Warnings. Product-specific hazard symbols and warnings not covered in this section may appear throughout the body of this manual where applicable.

WARNING

	<p>FIRE AND EXPLOSION HAZARD</p> <p>When flammable fluids are present in the work area, such as gasoline and windshield wiper fluid, be aware that flammable fumes can ignite or explode. To help prevent fire and explosion:</p> <ul style="list-style-type: none"> • Use equipment only in well ventilated area. • Eliminate all ignition sources, such as cigarettes and portable electric lamps. • Keep work area free of debris, including rags and spilled or open containers of solvent and gasoline. • Do not plug or unplug power cords or turn lights on or off when flammable fumes are present. • Ground all equipment in the work area. • Only use hoses that are compatible with the fluid you are dispensing. • Stop operation immediately if static sparking occurs or you feel a shock. Do not use equipment until you identify and correct the problem. • Keep a working fire extinguisher in the work area.
	<p>SKIN INJECTION HAZARD</p> <p>Pressurized fluid from dispensing device, hose leaks, or ruptured components will pierce skin. This may look like just a cut, but it is a serious injury that can result in amputation. Get immediate surgical treatment.</p> <ul style="list-style-type: none"> • Do not point dispensing device at anyone or at any part of the body. • Do not put your hand over the fluid outlet. • Do not stop or deflect leaks with your hand, body, glove, or rag. • Follow the Pressure Relief Procedure when you stop dispensing and before cleaning, checking, or servicing equipment. • Tighten all fluid connections before operating the equipment. • Check hoses and couplings daily. Replace worn or damaged parts immediately.

⚠ WARNING

	<p>EQUIPMENT MISUSE HAZARD</p> <p>Misuse can cause death or serious injury.</p> <ul style="list-style-type: none"> • Do not operate the unit when fatigued or under the influence of drugs or alcohol. • Do not exceed the maximum working pressure or temperature rating of the lowest rated system component. See Technical Data in all equipment manuals. • Use fluids and solvents that are compatible with equipment wetted parts. See Technical Data in all equipment manuals. Read fluid and solvent manufacturer's warnings. For complete information about your material, request MSDS from distributor or retailer. • Do not leave the work area while equipment is energized or under pressure. • Turn off all equipment and follow the Pressure Relief Procedure when equipment is not in use. • Check equipment daily. Repair or replace worn or damaged parts immediately with genuine manufacturer's replacement parts only. • Do not alter or modify equipment. Alterations or modifications may void agency approvals and create safety hazards. • Make sure all equipment is rated and approved for the environment in which you are using it. • Use equipment only for its intended purpose. Call your distributor for information. • Route hoses and cables away from traffic areas, sharp edges, moving parts, and hot surfaces. • Do not kink or over bend hoses or use hoses to pull equipment. • Keep children and animals away from work area. • Comply with all applicable safety regulations.
	<p>MOVING PARTS HAZARD</p> <p>Moving parts can pinch, cut or amputate fingers and other body parts.</p> <ul style="list-style-type: none"> • Keep clear of moving parts. • Do not operate equipment with protective guards or covers removed. • Pressurized equipment can start without warning. Before checking, moving, or servicing equipment, follow the Pressure Relief Procedure and disconnect all power sources.
	<p>TOXIC FLUID OR FUMES HAZARD</p> <p>Toxic fluids or fumes can cause serious injury or death if splashed in the eyes or on skin, inhaled, or swallowed.</p> <ul style="list-style-type: none"> • Read MSDSs to know the specific hazards of the fluids you are using. • Store hazardous fluid in approved containers, and dispose of it according to applicable guidelines.
	<p>PERSONAL PROTECTIVE EQUIPMENT</p> <p>Wear appropriate protective equipment when in the work area to help prevent serious injury, including eye injury, hearing loss, inhalation of toxic fumes, and burns. This protective equipment includes but is not limited to:</p> <ul style="list-style-type: none"> • Protective eyewear, and hearing protection. • Respirators, protective clothing, and gloves as recommended by the fluid and solvent manufacturer

Installation

Installation Notes

- A flexible hose connection must be used between the hose reel inlet and the source of the supply to prevent possible misalignment and binding.
- **Maximum Recommended Installation Height:**
 - XD40 - 15 feet (4.6 meters)
(See FIG. 4, page 11)
 - XD4010CMP - 8 feet (2.4 meters)
 - XD50 - 8 feet (2.4 meters)

Lifting Hose Reel

Always use a hoist or other suitable lifting device to raise hose reel into position.

Secure a lifting strap around spool as shown in FIG. 1. See Technical Data (page 31) for hose reel weights.

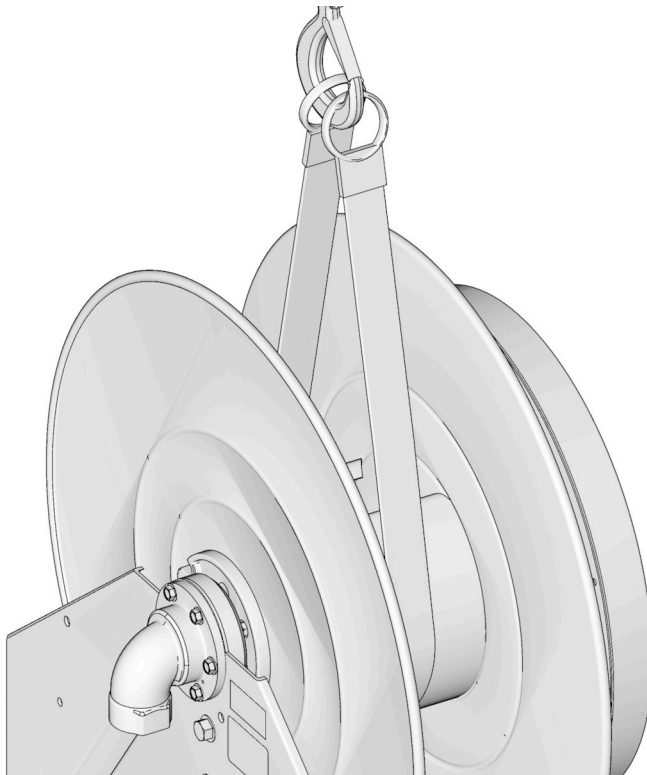





FIG. 1

Grounding

						
<p>The equipment must be bonded (grounded) to the truck. Grounding reduces the risk of static shock due to static build up on the equipment. Refer to your pump instruction manual for grounding instructions.</p>						

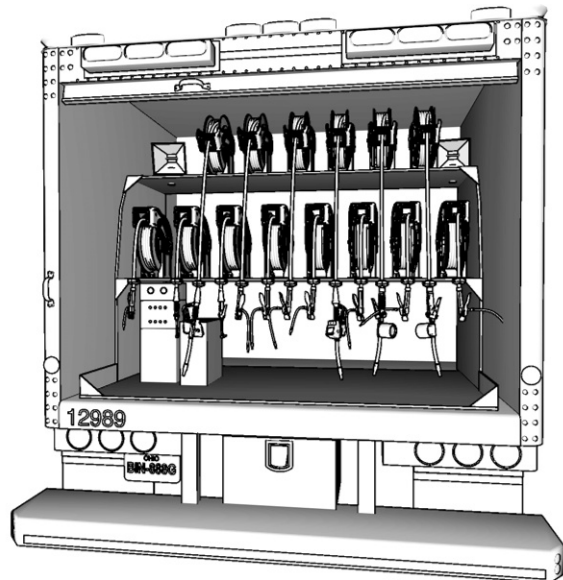

FIG. 2

Typical Layout

The installations shown in FIG. 3 and FIG. 4 are only a guide. Contact your Graco distributor for assistance in designing a system to suit your needs.

Truck-bed or Floor

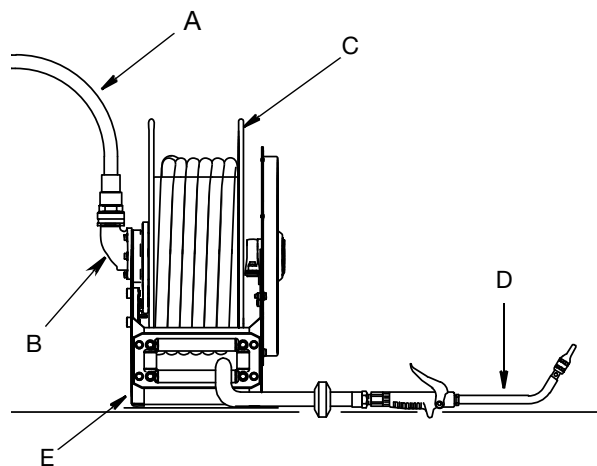

FIG. 3

Key:

- A To Pump
- B Fluid Inlet
- C Hose Reel
- D Dispense Valve
- E Mounting Channel

Overhead: XD40 only

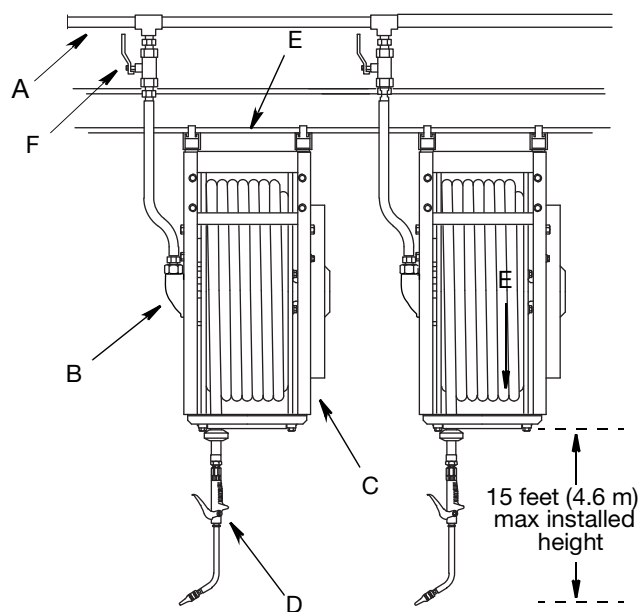

FIG. 4

Key:

- A To Pump
- B Fluid Inlet
- C Hose Reel
- D Dispense Valve
- E Mounting Channel
- F Fluid Shutoff Valve

Pressure Relief Procedure

NOTE: The following procedure is **NOT** used to remove tension from the spring. See Removing Spring Tension (page 17) for this procedure.



Follow the Pressure Relief Procedure whenever you see this symbol.



This equipment stays pressurized until pressure is manually relieved. To help prevent serious injury from pressurized fluid, such as skin injection, splashing fluid and moving parts, follow the Pressure Relief Procedure when you stop dispensing and before cleaning, checking, or servicing the equipment.

1. Turn off power supply to fluid pump.
2. Isolate the supply pump fluid supply line.
3. Open the dispensing valve until pressure is fully relieved.

If you suspect the dispensing valve or extension is clogged or that pressure has not been fully relieved after following the steps above, **VERY SLOWLY** loosen coupler or hose end coupling to relieve pressure gradually, then loosen completely. Clear the obstruction.

Hose Installation

NOTE: The following instructions assume this is a first time hose installation on a new bare reel. For Hose Replacement instructions, see Repair Manual, Removing the Hose instructions.

1. If the hose reel is not installed in a fixed location, use 2, large c-clamps (B) (one on the front and one on the back) to secure the hose reel to a flat surface (FIG. 5). Graco recommends placing a rag over the bottom roller and the back frame to protect these surfaces from damage when the c-clamps are tightened down.

NOTICE

The front c-clamp (B) should only be tightened enough to prevent the reel from moving. Overtightening this clamp could damage the bottom roller.

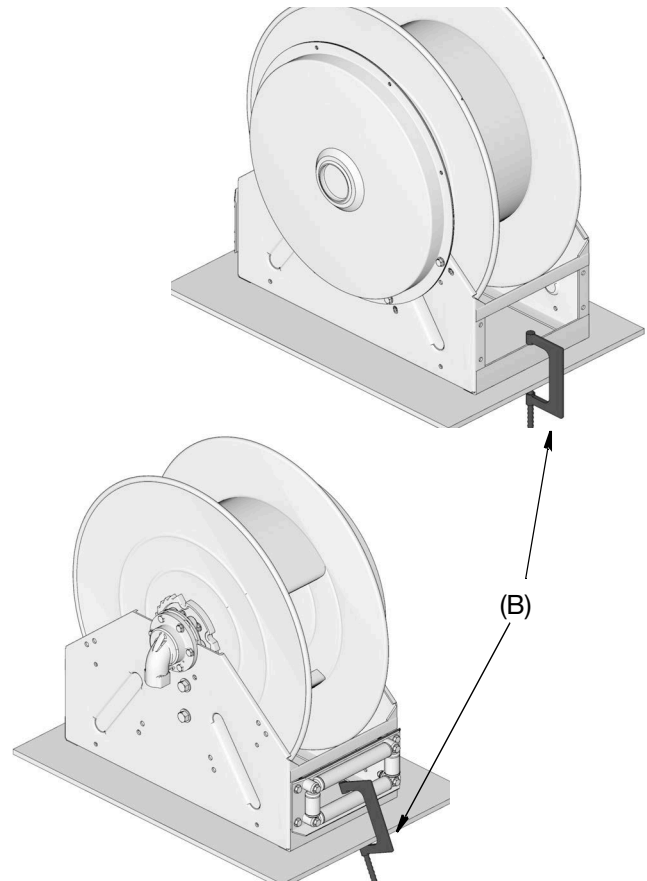

FIG. 5

2. Verify the spring is not under tension. If there is spring tension, follow Removing Spring Tension procedure provided on page 17.

3. For easier hose installation, Graco recommends removing the outlet (30) from the spool. To do this remove bolts (37) holding outlet to the spool (FIG. 6).
4. Apply pipe thread sealant or wrap PTFE tape around the threads of reducer (53) (if needed). Then install reducer (53) in the end of the outlet (FIG. 6). Use two wrenches on the flats, working in opposite directions, to securely tighten the reducer to the outlet fitting.

NOTE: A reducer (53) is not required for all installations. It is only necessary if the hose diameter is smaller than the diameter of the outlet (30).

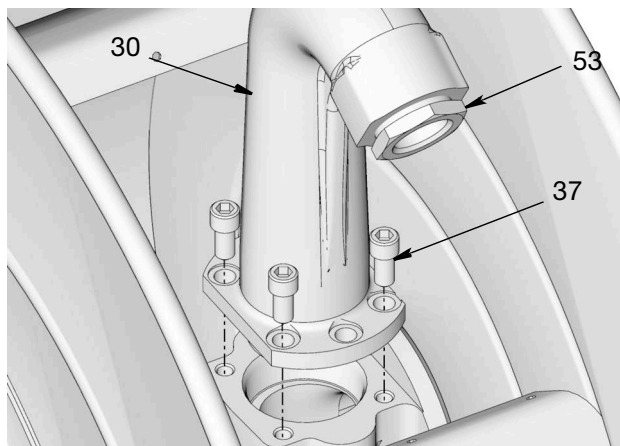

FIG. 6: Low Pressure Outlet shown. Medium Pressure models use 6 bolts.

5. Install the ball stop (45) near the end of the hose using screws (46) and nuts (47). Tighten nuts until the outside edges of the stop contact each other (FIG. 7).

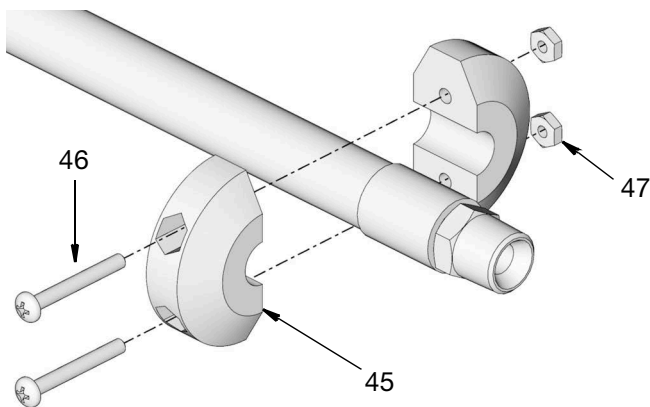

FIG. 7

<ul style="list-style-type: none"> • Never allow the reel to spin freely. Doing so causes the spool to spin out of control, which could cause serious injury if you are hit by the hose. • Always wear heavy, non-slippery gloves when adjusting the spring tension to protect your hands from being cut on the hose reel. 						

6. Uncoil and extend hose.
7. Feed opposite end of the hose, through the rollers (a), then under the reel (b), and around the back (c) of the spool.

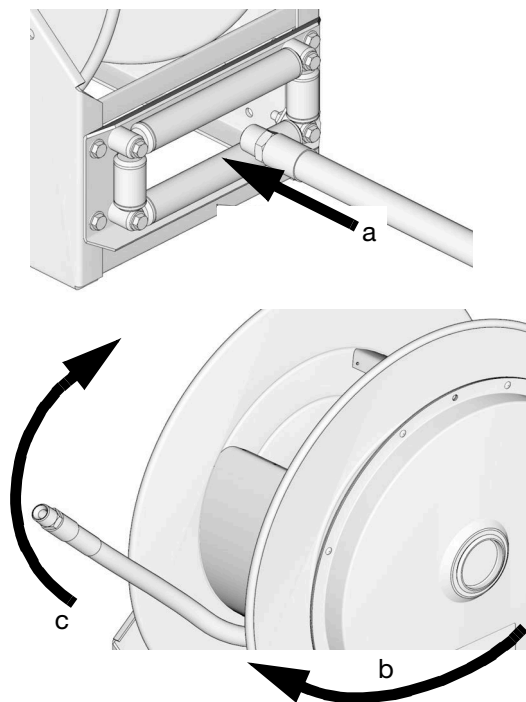

FIG. 8

8. Apply pipe thread sealant or wrap hose threads with PTFE tape.

- Attach end of the hose to the outlet (30) using two wrenches on the flats, working in opposite directions, to securely tighten the hose to the outlet fitting (FIG. 9).

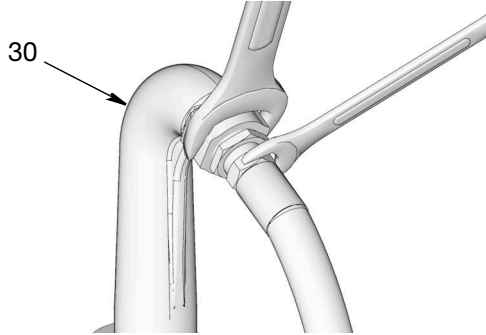

FIG. 9

- Place a piece of tape on the side of the reel flange as a visual reference point for counting reel rotations.
- Pre-wind hose reel as needed to accommodate the length of hose you are installing. Refer to Table 1, Spring Tension and Pre-Turns, page 34 to determine the number of turns needed for your hose and reel model.

NOTE: Wind direction is determined by the direction the spool rotates when the hose is extended during operation.



Never allow the reel to spin freely. Doing so causes the spool to spin out of control, which could cause serious injury if you are hit by the hose or dispense valve.

- Engage the latch. Listen for the loud click when the spool has latched.

- Securely attach a c-clamp (A) to the reel spool as shown in FIG. 10 to help prevent the reel from unintentionally becoming unlatched and spinning freely.

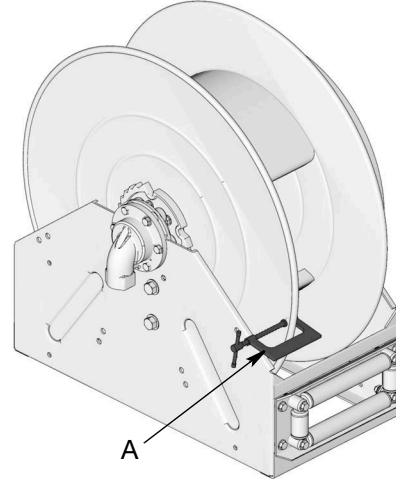

FIG. 10

- Verify outlet o-ring (34) is in place on outlet (30). Apply a thin layer of grease (G) to o-ring as shown in FIG. 11.

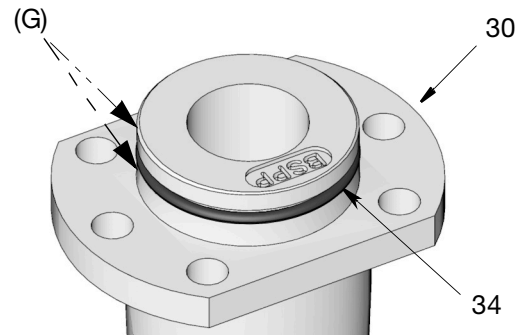

FIG. 11

15. Install outlet (30) to spool. Replace and tighten all bolts (37) securely. Torque bolts to 24 to 30 ft. pounds (32.54 to 40.67 N.m) (FIG. 12).

NOTE:

- Low Pressure Models (shown in FIG. 12) use 4 bolts (37).
- Medium Pressure Models (not shown) use 6 bolts (37).
- Always use all bolts provided.

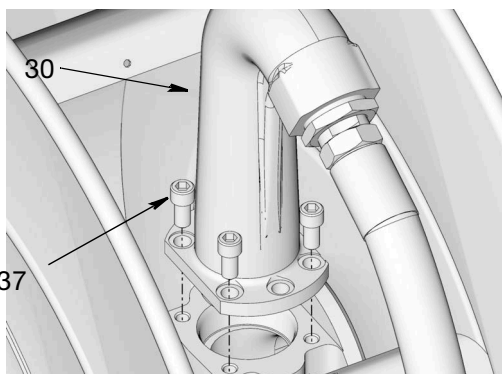

FIG. 12: Low Pressure Model Shown.

16. Remove c-clamp (A) (installed in Step 12, page 14).
17. Disengage latch by pulling on hose to release it.

Always wear heavy, non-slippery gloves when adjusting the spring tension to protect your hands from being cut on the hose reel.						

18. Use your hand to guide the hose as it rewinds onto the reel.
19. Adjust spring tension if needed. See Adjusting Spring Tension, page 15.
20. Install dispense valve to end of hose.

Adjusting Spring Tension

If the hose cannot be pulled all the way out or if it does not retract all the way back onto the hose reel, you need to adjust the spring tension.

<ul style="list-style-type: none"> • Never allow the reel to spin freely. Doing so causes the spool to spin out of control, which could cause serious injury if you are hit by the hose. • Always wear heavy, non-slippery gloves when adjusting the spring tension to protect your hands from being cut on the hose reel. 						

--	--	--	--	--	--	--

1. If the hose reel has been in service, relieve pressure, page 12.
2. Pull the hose out far enough to engage the latch.

NOTE: Listen for the loud click when the spool has latched.

3. Attach a c-clamp (A) to the reel spool as shown in FIG. 13 to help prevent the reel from unintentionally becoming unlatched and spinning freely.

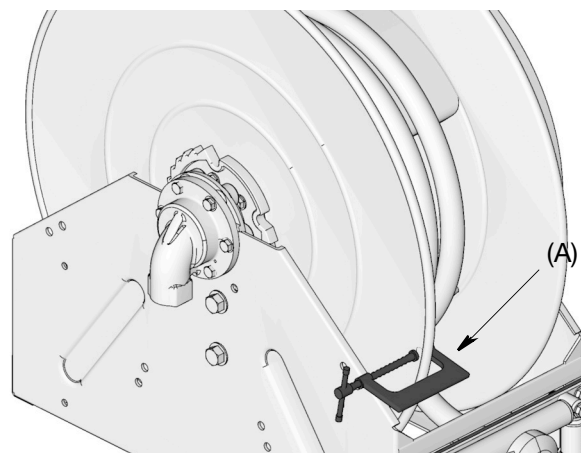

FIG. 13

If a ball stop and dispensing device are **NOT** installed on the hose end, skip Step 4 and continue instructions with Step 5.

- Remove dispense valve, nuts (47), screws (46) and ball stop (45) from end of hose (FIG. 18).

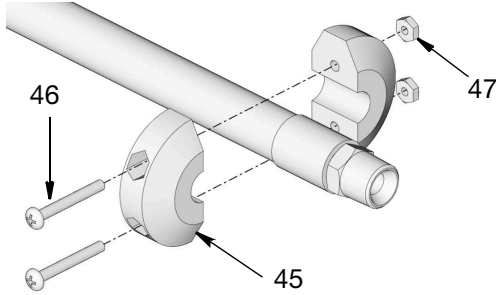

FIG. 14

- Feed the loose end of the hose through the hose rollers and manually wrap and secure the hose onto the reel.

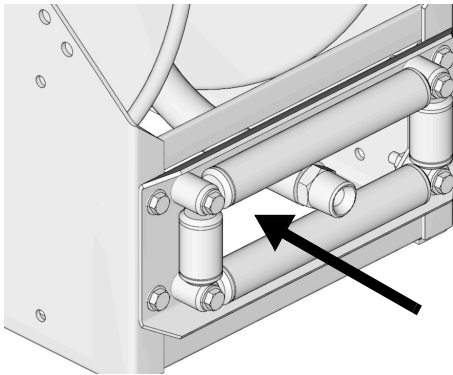

FIG. 15

- Place tape on the side of the reel flange as a visual reference point for counting reel rotations.
- Remove c-clamp (A) installed in Step 3.
- Rotate reel spool keeping the hose wrapped on the reel.

NOTE:

- Each rotation of the reel spool increases or decreases enough spring tension to retract or let out approximately 5 feet (1.5 m) of hose.
 - Wind spring, in one turn increments, tighter to increase tension.
 - Unwind spring, in one turn increments, to decrease spring tension.
- Refer to the Table 1: Spring Tension and Pre-turns (page 34) to determine the number of spool rotations needed to correctly set the spring tension for your reel model and hose.

- Check the spring tension. When it is set correctly after pulling the hose completely off the spool it will retract fully.

NOTICE

Always hold on to the hose while it is rewinding to avoid damage to the reel.

- Repeat Steps 8 and 9 until you have the proper amount of spring tension.

NOTICE

Do not increase the spring tension so much that the spring winds up tightly before the hose is fully extended. A spring that is wound too tightly:

- Stops the reel from rotating before the hose is fully extended, which puts excessive strain on the hose and reel spring.
- Can cause the latch and ratchet to lock, making disengagement by pulling the hose impossible.

- Rotate spool to engage latch to prevent spool rotation or unwinding.
- Securely attach a c-clamp (A) to the reel spool as shown in FIG. 13 to help prevent the reel from unintentionally becoming unlatched and spinning freely.
- Route end of the hose through the hose rollers (FIG. 16).

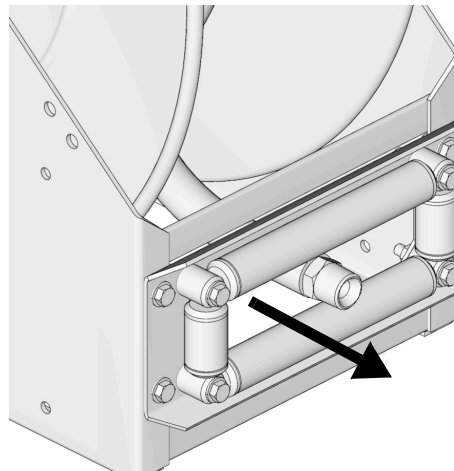
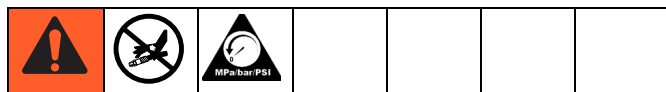

FIG. 16

- Reinstall ball stop and dispensing valve (FIG. 14).
- Remove c-clamp (A).
- Pressurize hose reel and reverify spring tension.

Removing Spring Tension



1. If the hose reel has been in service, relieve pressure, page 12.



Always wear heavy, non-slippery gloves when adjusting the spring tension to protect your hands from being cut on the hose reel.

2. Pull the hose out far enough to engage the latch.
NOTE: Listen for the loud click when the spool has latched.
3. Attach a c-clamp (A) to the reel spool as shown in FIG. 17 to help prevent the reel from unintentionally becoming unlatched and spinning freely.

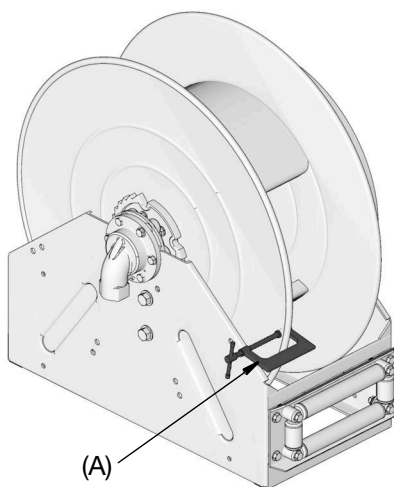

FIG. 17

4. Remove dispense valve, nuts (47), screws (46) and ball stop (45) from end of hose (FIG. 18). Cap end of hose (if needed) to prevent fluid spills.

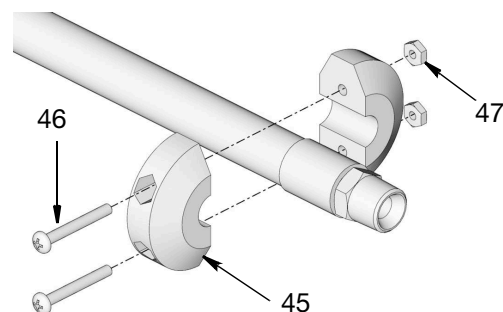

FIG. 18

5. Feed loose end of hose through the hose rollers and manually wrap and secure hose onto reel (FIG. 19).

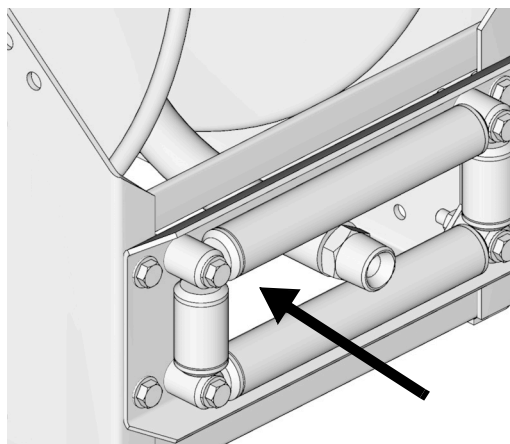

FIG. 19

6. Place a piece of tape on the side of the reel flange as a visual reference point for counting reel rotations.
7. Remove c-clamp (A).
8. Rotate spool in the tightening direction to disengage latch.
9. Use your hands to unwind reel by rotating the spool in the opposite direction turned in step 8, until it the reel reaches a free state. Always keep at least one hand on the spool to prevent free-spool rotation.

NOTE: Count the number of turns while unwinding the spool and record the number for use when retensioning the spring later.

Inlet Orientation

- In all installations Graco recommends adjusting the orientation of the inlet prior to installing the hose reel.
- If the hose reel is installed on a flat surface, such as a truck bed, the reel does not have to be removed from it's service location to change the inlet orientation.
- Inlet (6) is designed with a weep hole (a) (FIG. 20) to indicate a failed seal.

Bare Reels Only (without hose installed)

<p>Never allow the reel to spin freely. Doing so causes the spool to spin out of control, which could cause serious injury.</p>						

1. Before changing inlet orientation, verify the spring is not under tension by performing the Removing Spring Tension procedure, page 17.

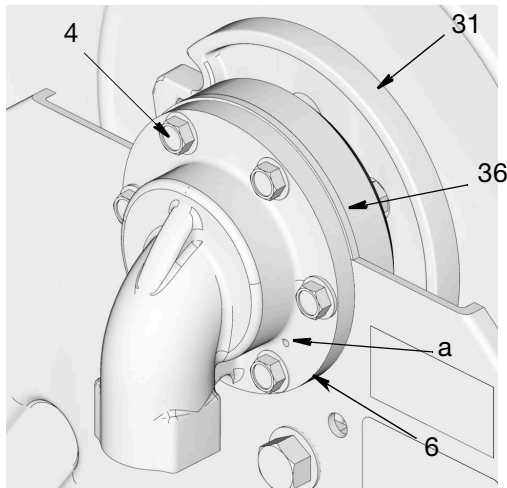

FIG. 20

2. Remove six bolts (4) (FIG. 20).

NOTE:

- It is not necessary to remove inlet (6) to change it's position.
- Medium Pressure Models ONLY: The shim (36) may move out of place behind the outlet when the bolts are removed. Do not lose this piece. It will be needed for reassembly after the outlet location is adjusted.

3. Rotate inlet (6) to desired location.

NOTE: The inlet can be rotated and set to 6 possible positions.

4. Medium Pressure Models ONLY: Align shim (36) between inlet (6) and bearing retainer (35) (FIG. 21).

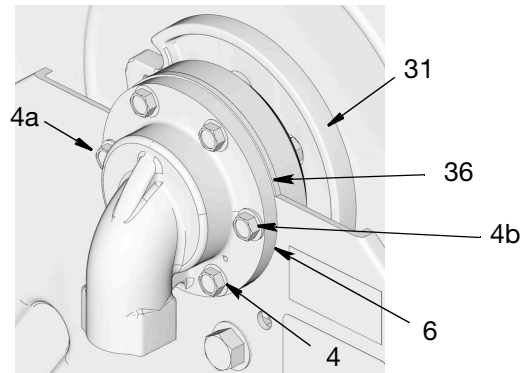

FIG. 21

5. First install the side 2 bolts (4a and 4b) as shown in FIG. 21 through frame and inlet (6). Tighten bolts just enough to hold everything in place.
6. Then install the remaining four bolts (4). Hand tighten and then torque all bolts to 25 to 35 ft. lbs (33.9 to 47.45 N•m).

Reels with Hoses Installed

--	--	--	--	--	--	--

1. Relieve pressure, page 12.
2. Disconnect inlet hose from inlet fitting (6).

<p>Never allow the reel to spin freely. Doing so causes the spool to spin out of control, which could cause serious injury if you are hit by the hose.</p>						

3. Overhead or wall mounted hose reels must be removed from service and secured to a flat surface (B, FIG. 22) before changing the inlet orientation.

NOTE: To secure hose reel to a flat surface use 2 large c-clamps (B) (one on the front and one on the back). Graco recommends placing a rag over the bottom roller and the back frame to protect these

surfaces from damage when the c-clamps are tightened down.

NOTICE

The front c-clamp (B) should only be tightened enough to prevent the reel from moving. Overtightening this clamp could damage the bottom roller.

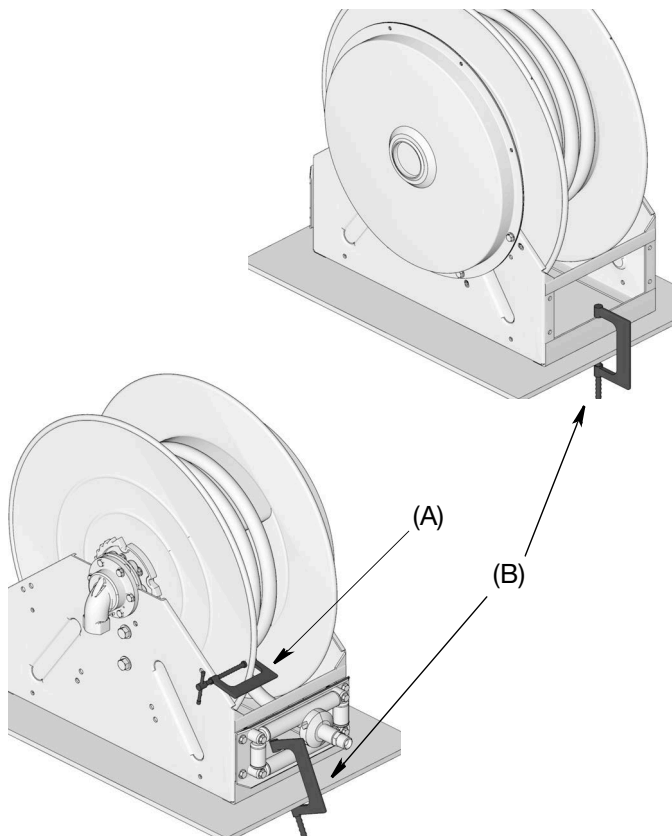

FIG. 22

4. The hose must be fully retracted before starting this procedure. Be sure the ball stop is in place to help prevent the reel from unintentionally spinning.
5. Engage latch. Securely attach a c-clamp (A) to the spool as shown in FIG. 22 to help prevent the reel from unintentionally spinning freely.

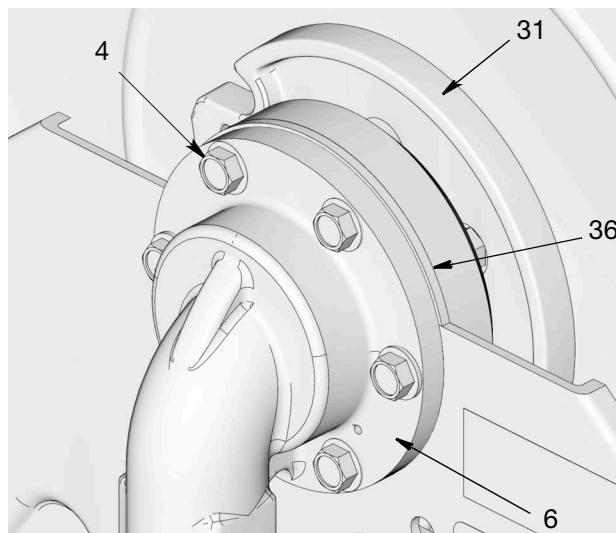

FIG. 23

6. Remove six bolts (4).

NOTE: Medium Pressure Models ONLY: The shim (36) may move out of place behind the outlet when the bolts are removed. Do not lose this piece. It will be needed for reassembly after the outlet location is adjusted.

7. Rotate inlet (6) to desired location.

NOTE: The inlet can be rotated and set to 6 possible positions.

8. Medium Pressure Models ONLY: Align shim (36) between inlet (6) and bearing retainer (5).

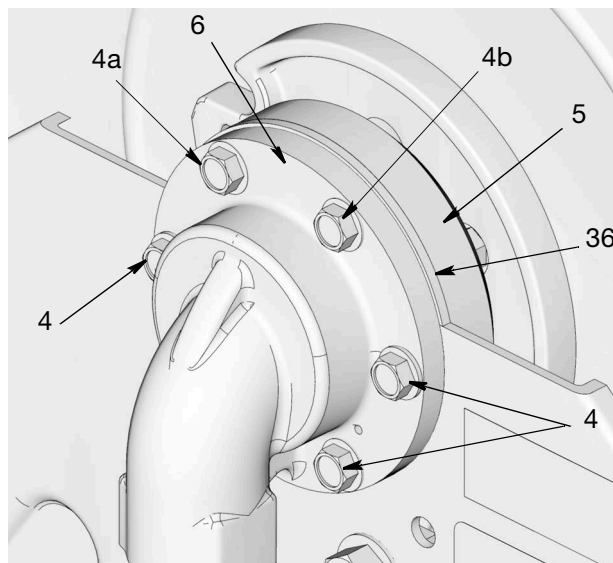

FIG. 24

9. First install the top 2 bolts (4a and 4b), through the frame and inlet (6), as shown in FIG. 24. Tighten bolts just enough to hold everything in place.
10. Then install the remaining bolts (4). Hand tighten and then torque all bolts to 25 to 35 ft. lbs (33.9 to 47.45 N•m).
11. Remove c-clamp.

NOTICE
Always hold on to the hose while it is rewinding to avoid damage to the reel.

12. If necessary, adjust spring tension. See Adjusting Spring Tension instructions, page 15.

Mounting Options

All Mountings

NOTE:

- Always use large flat washers with the bolts you use to mount the hose reel pedestal to any surface.
- In overhead or wall mounted installations, if the inlet orientation requires adjustment, change the orientation of the inlet prior to installing the hose reel. See Inlet Orientation, page 18.
- In overhead installations, the hose should be installed on the reel before you mount the reel. See Hose Installation, page 12, if the hose is not already installed on the reel.

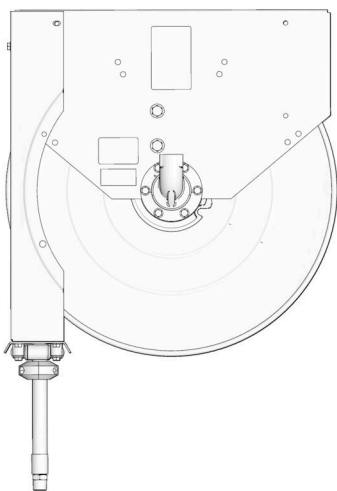

FIG. 25: Overhead installation shown

XD40 Models Only - Overhead Mounting

Use Graco Overhead Mounting Kit 237932 for mounting the hose reel base to an overhead I-beam. Contact your Graco distributor or Graco Customer Service for additional information about this kit.

<ul style="list-style-type: none"> • To reduce the risk of injury when mounting a hose reel overhead, always use a lift truck. • Be sure the mounting surface is strong enough to support the reel, the weight of the lubricants and the stress caused by hard pulls on the service hoses. 					

For the following Steps, refer to FIG. 26.

1. Install hose on reel prior to installation. See Hose Installation, page 12.
2. Verify spring tension is set correctly. See Adjusting Spring Tension, page 15.
3. Adjust inlet orientation if needed. See Inlet Orientation, page 18.
4. Install roller arm supports using Roller Arm Kit 24R076 (XD40) or 24R077 (XD50). Instructions for this procedure are provided in the Roller Arm Kit and should be used for this installation.
5. Select the reel mounting location.
 - For high ceilings, suspend a suitable support structure for the reels so the hoses will be long enough to reach the service area.
 - Do not exceed installation height of 15 ft. (4.57 m).
6. Position the hose reel so the mounting brackets (included in Kit 237932) are facing up.

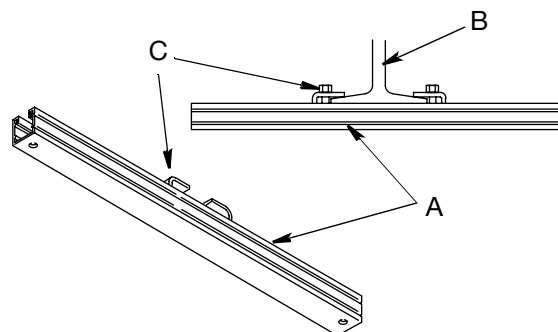

FIG. 26

7. Line up the 4 holes on the hose reel mounting base with the holes near the ends of the mounting brackets (A) (FIG. 26) and securely bolt the hose reel to the mounting brackets.
8. Using a lift truck, raise the hose reel as close to the I-beam as possible.
9. Position adjustable clamps (C) of the mounting brackets on the flanges of the I-beam (B) (FIG. 26). Securely tighten clamps to 10 ft. lbs (13.5 N.m).
10. Connect the supply line to the inlet of the reel.
11. Be sure the reel is securely mounted before lowering the lift truck.

Hose Exit Configurations

Truck / Bench Hose Extending from Under Spool

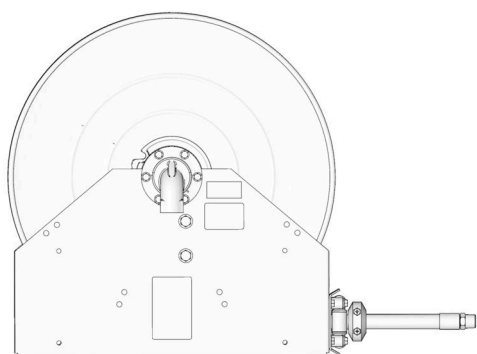

FIG. 27

Wall Mounted with Hose Extending Close to Wall

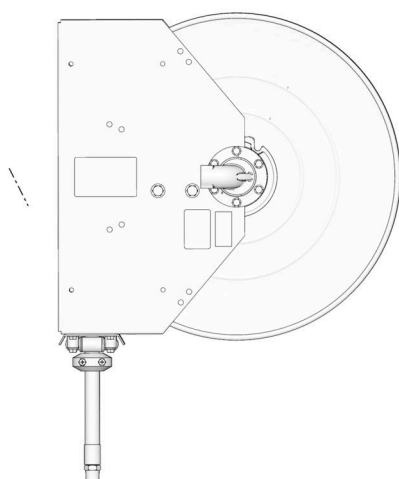

FIG. 28

Truck / Bench Hose Extending from Topside of Spool

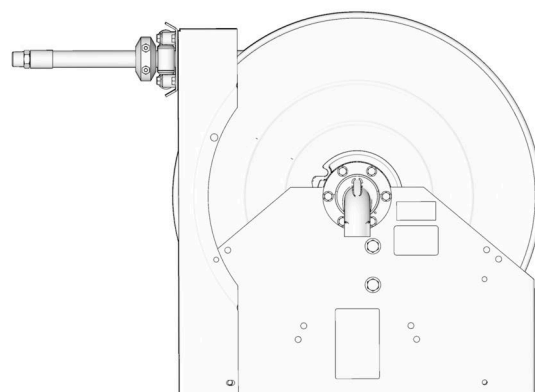

FIG. 29

Wall Mounted with Hose Extending Away From Wall

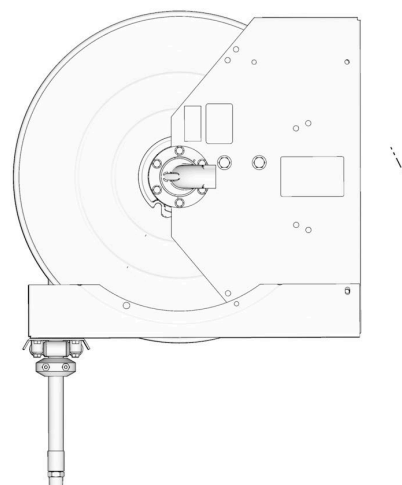

FIG. 30

Roller Support Arm Kits: 24R076, 24R077

Hose reels are shipped with the hose rollers bolted near the reel mounting base, which is the proper position for truck-mounted hose reels with hose exit positioned under the spool.

To mount the reel overhead or with the hose exit position over the spool, install support arms to the reel. Order Support Arm Kit: 24R076 (XD40 models) or 24R077 (XD50 models). See Related Kits, page 30 or contact Graco Customer Support for additional information about these kits.

Installation instructions are included in the roller support arm kit and should be used for this installation.

Installing Inlet Hose

Use Graco Inlet Hose Kits: 24R111, 24R112, 24R115 or 24R117. See Related Kits, page 30.

NOTICE

A flexible hose connection must be used between the hose reel inlet and the fluid supply hose to prevent possible misalignment and binding.

1. Apply pipe thread sealant or wrap PTFE tape around the threads of a (user supplied) union adapter.
2. Attach union adapter to inlet hose. Use a wrench to tighten the connection.
3. Attach inlet hose to inlet (6) (FIG. 31).

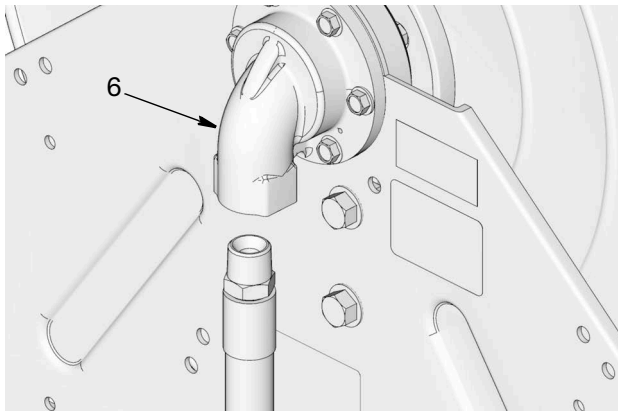

FIG. 31

4. Use a wrench to support the inlet fitting while tightening the hose.
5. Flush system by pumping dispensing fluid through line until all solvent has been flushed out (See Flushing instructions, page 23.)

Flushing



Before installing dispense valve to end of hose, flush supply line with the fluid you are dispensing.

1. Place end of hose in a waste container.

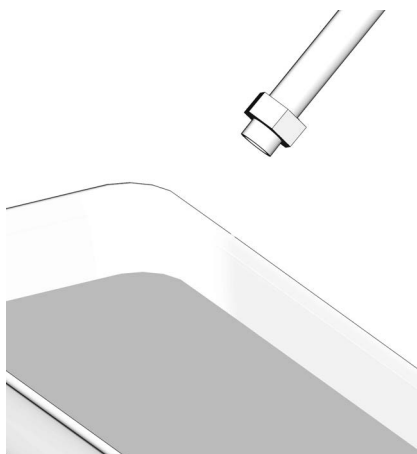

FIG. 32

2. Blow out entire lubricant supply line with air.

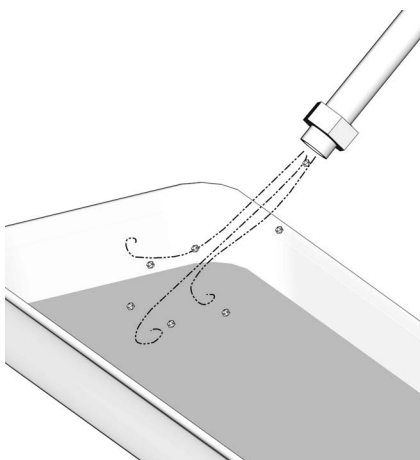

FIG. 33

3. Flush equipment with a compatible solvent until fluid runs clear.

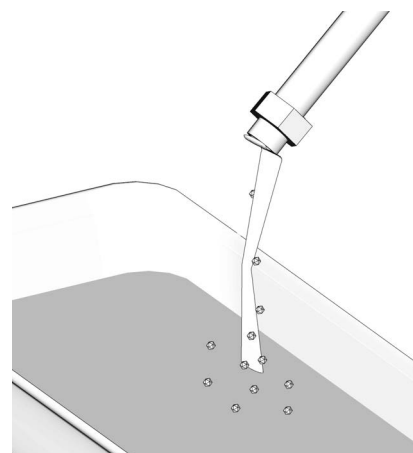

FIG. 34

4. Pump dispensing lubricant through line until all solvent is flushed out.

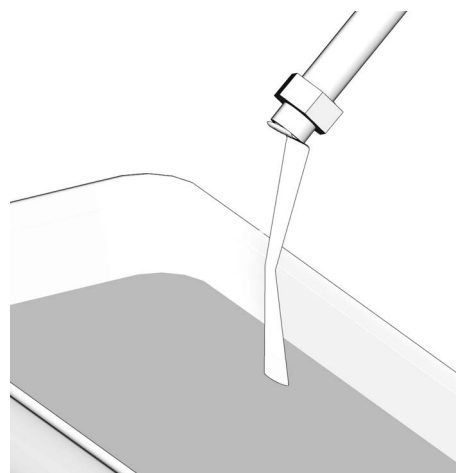







FIG. 35

Operation

						
<p>SLIPPERY SURFACE HAZARD</p> <p>Wet, snow-covered or icy surfaces could result in serious injury due to slipping or falling when pulling the hose off the reel. To prevent injury:</p> <ul style="list-style-type: none"> • If possible walk on a dry or stable surface. • If you must walk on a slippery surface, wear proper footwear for better traction. 						

Check reel for correct operation by slowly pulling out the hose. A clicking sound indicates each full revolution.

						
---	---	--	--	--	--	--

1. Turn on the fluid and/or air supply to the hose.
2. Pull out the hose and allow it to retract slowly until you hear a click and the reel latches.

NOTE: If the reel does not latch, pull the hose out and retract it again.

Hose Reel Retraction

The XD40 and XD50 hose reels provide adequate retraction capability at generally accepted industry standard operating pressures by providing a balance between the retraction capability and hose extension forces.

Hose reel retraction is a function of:

- the spring pre-load setting
- hose stiffness*
- operating pressure
- dispense valve weight
- amount of vertically hanging hose

* Use of a stiffer hose than the Graco standard hose offering (Parts, Ref. 44) may result in poor retraction due to the increased hose stiffness.

See the Troubleshooting section of this manual, page 25 to identify possible hose retraction problems and solutions related to those problems.

Retracting the Hose

1. Pull on the hose to release the latch.
2. Without letting go of the hose, allow the hose to retract.

Troubleshooting



Problem	Cause	Solution
Poor Retraction	Power spring not correctly adjusted	Increase spring pre-load. See Adding Spring Tension, page 15.
	Hose too stiff	Use correct hose for application. See Parts, beginning on page 28 for the correct hose for you application.
	Excessive swivel friction and hose bending torque	Reduce operating pressure.
	Excessive hanging weight of hose and dispense valve	Reduce installation height to recommended values. Do not exceed installation height of 15 ft. (4.57 m). See Parts, beginning on page 28 for the correct hose for you application.
	Incorrect hose reel / spring for the application	Use recommended reel/spring combination for application.
		Do not use low pressure (LP) reels for medium pressure oil dispense.
	Swivel bearing failure	Rebuild or replace swivel bearing. See XD40/XD50 Repair manual.
Spring bearing failure	Rebuild or replace spring bearing. See XD40/XD50 Repair manual.	
Excessive Hose Extension Forces	Power spring not correctly adjusted	Decrease spring pre-load. See Adjusting Spring Tension, page 15.
	Excessive swivel friction	Reduce operating pressure.
	Design constraints exceeded for spring reel	Select a power reel for the application.
Fluid leakage from inlet housing weep hole	Worn swivel seal	Replace seal. See FIG. 20, page 18 and the XD40/XD50 Repair manual.
Reel doesn't latch.	Latch pawl broken	Replace latch. See XD40/XD50 Repair manual.
Reel doesn't retract hose all the way	Power spring broken.	Replace spring canister. See XD40/XD50 Repair manual.
	Spring hub key broken.	Replace key. See XD40/XD50 Repair manual.
Fluid leakage from outlet seal	Seal failed	Replace outlet seal. See XD40/XD50 Repair manual.

XD40/XD50 Parts Drawing

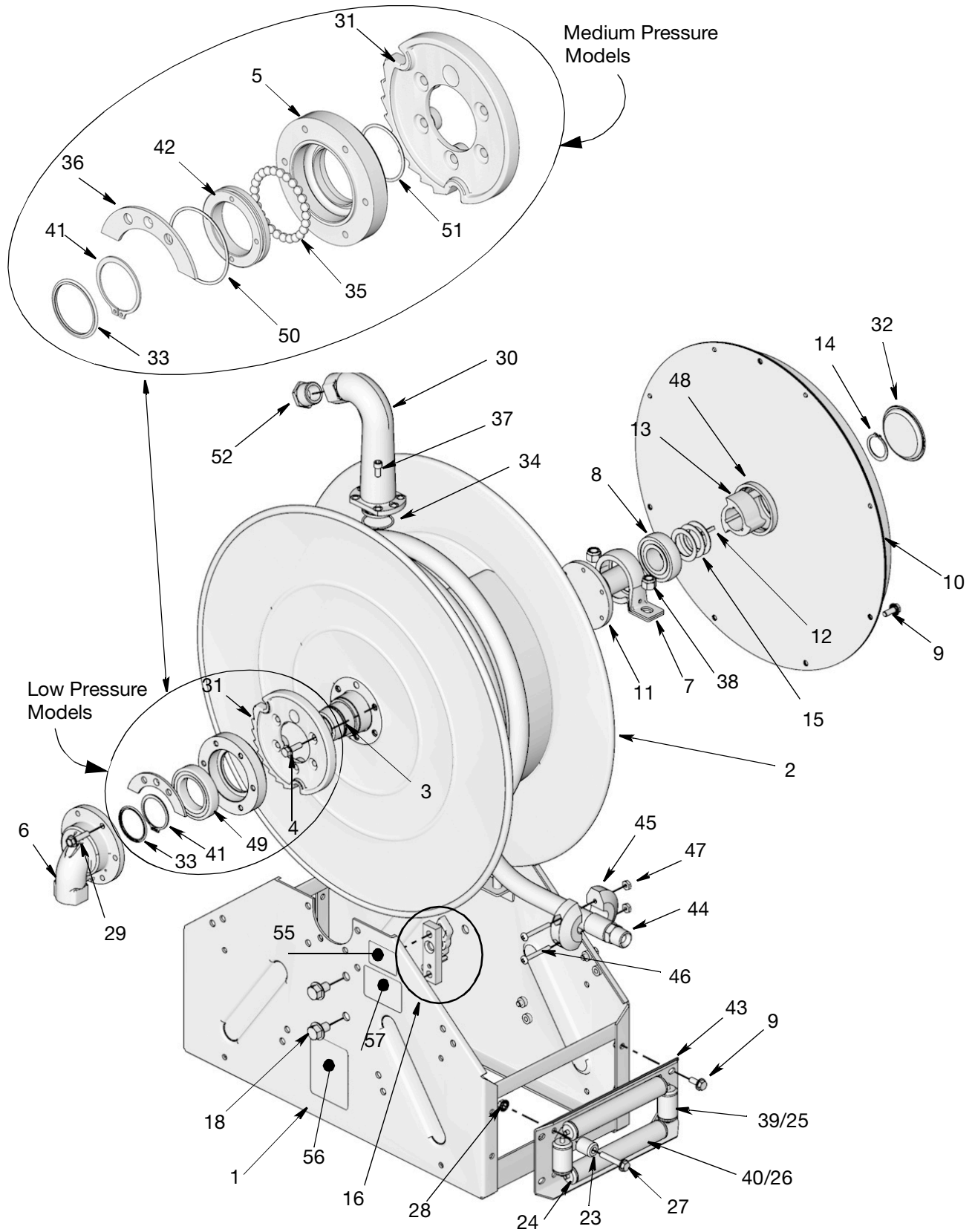

XD40/XD50 Parts List

Ref	Part No.	Description	Qty
1		BASE, reel	1
2		SPOOL, hose reel, XD40 models	1
3	16P906^	SWIVEL, Low Pressure models	1
	16P907\$	SWIVEL, Medium Pressure models	1
4\$&@	112586	SCREW, cap, hex head, Low Pressure models	11
		SCREW, cap, hex head, Medium Pressure models	5
5@	16P901	RETAINER, bearing, Medium Pressure models	
6✓		SWIVEL, inlet	1
7α		RETAINER, bearing, pillow block	1
8α	112953	BEARING, ball	1
9★¥ζ	110963	SCREW, cap, flange head	14
10†		SPRING, enclosed	1
11	126150¥	SHAFT, XD40, low pressure, C and D springs	1
	126151ζ	SHAFT, XD 40, Medium Pressure and ALL XD50 low and medium pressure , A and B springs	1
12†α¥ζ	113267	KEY, square	1
13†		HUB, reel, XD40, low pressure, C and D springs	1
		HUB, reel, XD 40, Medium Pressure and ALL XD50 low and medium pressure , A and B springs	1
14†α¥ζ	106082	RING, retaining	1
15α		SPACER, spring, hub	3
16❖	24R066	KIT, latch	1
18❖		SCREW, latch	2
23❖★§	126757	POST, corner	4
24★§	190376	CAP, roller	8
25★§	190378	TUBE, roller, XD40, 1 inch hose and smaller	2
	16P123	TUBE, roller, XD50, 1-1/4 and 1-1/2 inch hoses	2
26★§	190377	TUBE, roller	2
27★§	112960	SCREW, cap, flange head	4
28★	110996	NUT, hex, flange head	8

Ref	Part No.	Description	Qty
29	126596	SCREW, cap, hex head, Low Pressure models	6
30‡*		SWIVEL, outlet	1
31&	16P903	RATCHET	1
32†α^ \$¥ζ	112961	CAP, end	1
33✓	129038	SEAL, XD inlet, general, FKM	1
	126787	SEAL, XD, inlet, antifreeze, Buna-n	1
34‡*	105318	PACKING, o-ring	1
35@		BALL, chrome, 0.375, grade 10, Medium Pressure models	21
36		SHIM, frame, Medium Pressure models	1
37‡*	108751	SCREW, cap, low pressure	4
	108751	SCREW, cap, medium pressure	6
38α		NUT, nylock, st, 1/2 - 13, zinc	2
39★§	167030	PIN, roller, XD40 models, 1 inch hose and smaller	2
	16P124	PIN, roller, XD50 models, 1-1/4 and 1-1/2 inch hoses	2
40★§	190363	PIN, roller	2
41* @	126643	RING, retaining, 1.969 shaft	1
42@		INSERT, bearing, medium pressure	1
43★	16T624	PLATE, roller, XD40 models, 1 inch hose and smaller	1
	16P081	PLATE, roller, XD50 models, 1-1/4 and 1-1/2 inch hoses	1
44	126359	HOSE, coupled, 1/2 inch x 100 ft, air/water, npt, XD40 models, XD4010DLP	1
	126360	HOSE, coupled, 3/4 inch x 75 ft, air/water, npt, XD40 models, XD4010DLP	1
	126361	HOSE, coupled, 3/4 inch x 100 ft, air/water, npt, XD40 models, XD4010CLP	1
	126362	HOSE, coupled, 1 inch x 50 ft, air/water, npt, XD40 models, XD4010DLP	1
	26C124	HOSE, coupled, 1/2 inch x 100 ft, oil, npt, XD40 models, XD4010AMP	1

Ref	Part No.	Description	Qty
	126376	HOSE, coupled, 3/4 inch x 75 ft, oil, npt, XD40 models, XD4010BMP	1
44 (cont)	126377	HOSE, coupled, 3/4 inch x 100 ft, oil, npt, XD40 models, XD4010AMP	1
	126503	HOSE, coupled, 1 inch x 50 ft, oil, npt, XD40 models, XD4010BMP	1
	126379	HOSE, coupled, 1 inch x 50 ft, waste oil evacuation, npt, XD40 models, XD4010CLP	1
	24R102	HOSE, coupled, 1 inch x 50 ft, fuel, npt, XD40 models, XD4010-CLP	1
	126363	HOSE, coupled, 1 inch x 75 ft, air/water, npt, XD50 models, XD5010ALP	1
	126364	HOSE, coupled, 1 inch x 100 ft, air/water, npt, XD50 models, XD5010ALP	1
	126504	HOSE, coupled, 1 inch x 75 ft, oil, npt, XD50 models, XD5010AMP	1
	126380	HOSE, coupled, 1.25 inch x 35 ft, waste oil evacuation, npt, XD50 models, XD5015BLP	1
	126688	HOSE, coupled, 1.25 inch x 50 ft, waste oil evacuation, npt, XD50 models, XD5015BLP	1
	24R103	HOSE, coupled, 1 inch x 75 ft, fuel, npt, XD50 models, XD5010BLP	1
	24R106	HOSE, coupled, 1 inch x 100 ft, fuel, npt, XD50 models, XD5010ALP	
	24R108	HOSE, coupled, 1.25 inch x 35 ft, fuel, npt, XD50 models, XD5015BLP	1
	24R110	HOSE, coupled, 1.25 inch x 50 ft, fuel, npt, XD50 models, XD5015BLP	1
	24R114	HOSE, coupled, 1.25 inch x 50 ft, fuel, npt, XD50 models, XD5015ALP	1
45◆		STOP, hose	2
46◆	117588	SCREW, machine, phil, pan head	2
47◆	101324	NUT, hex, jam	2

Ref	Part No.	Description	Qty
48†□^ \$¥¿	126467	SEAL, dust	1
49*	24R514	RETAINER, bearing	1
50@	16W910	O-RING, buna	1
51@	126731	O-RING, buna	1
52✕	100380	FITTING, bushing, reducer /2 inch x 1 inch npt	1
	502851	FITTING, bushing, reducer, 3/4 inch x 1 inch npt	1
	121446	FITTING, bushing, reducer, 1-1/4 inch x 1-1/2 inch npt	1
55		LABEL, identification	1
56	16T815	LABEL, XD40	1
57▲	15W036	LABEL, warning	1

▲ Replacement Danger and Warning labels, tags and cards are available at no cost.

See the Related Kits Table provided on page 30, to identify the correct kit to use for your hose reel model.

‡ Parts are included in Outlet Kit 24R056, 24R057, 24R059, 24R665, 24R666, 24R667, 24R668, 24R670, 24R673.

✕ Parts are included in Outlet Kit 24R053, 24R055, 24R058.

◆ Parts are included in Ballstop Kit 222225, 218341, 237872, 24R060, 24R061.

† Parts are included in Power Spring Kit 24R062, 24R063, 24R064, 24R065.

❖ Parts are included in Latch Kit 24R066.

✓ Parts are included in Inlet Kit 24R067, 24R068, 24R674, 24R675, 24R677, 24R678, 129137.

* Parts are included in Low Pressure Bearing Kit 24R070.

@ Parts are included in Medium Pressure Bearing Kit 24R071.

★ Parts are included in Roller Guide Kit 24R072, 24R074.

§ Parts are included in Roller Guide Kit 24R073, 24R075.

□ Parts are included in Spring Side Bearing Kit 24R339.

^ Parts are included in Low Pressure Swivel Kit 24R336.

\$ Parts are included in Medium Pressure Swivel Kit 24R337.

& Parts are included in Ratchet Kit 24R338.

¥ Parts are included in C and D Spring Shaft Replacement Kit 24R953.

¿ Parts are included in A and B Spring Shaft Replacement Kit 24R954.

Related Kits

Part No.	Description
24R053	KIT, outlet, 1/2 inch, npt, XD40, includes parts 30, 34, 37, 52
24R055	KIT, outlet, 3/4 inch, npt, XD40, includes parts 30, 34, 37, 52
24R056	KIT, outlet, 1 inch, npt, XD40, includes parts 30, 34, 37
24R057	KIT, outlet, 1 inch, npt, XD50, includes parts 30, 34, 37
24R058	KIT, outlet, 1-1/4 inch, npt, XD50, includes parts 30, 34, 37, 52
24R059	KIT, outlet, 1-1/2 inch, npt, XD50, includes parts 34, 30, 37
24R665	KIT, outlet, 1 inch, BSPP, XD40, includes parts 30, 34, 37
24R666	KIT, outlet, 1 inch, BSPT, XD40, includes parts 30, 34, 37
24R667	KIT, outlet, 1 inch, BSPP, XD50, includes parts 30, 34, 37
24R668	KIT, outlet, 1 inch, BSPT, XD50, includes parts 30, 34, 37
24R670	KIT, outlet, 1.5 inch, BSPP, XD50, includes parts 30, 34, 37
24R673	KIT, outlet, 1.5 inch, BSPT, XD50, includes parts 30, 34, 37
222225	KIT, ballstop, 1/2 inch, includes parts 45, 46, 47
218341	KIT, ballstop, 3/4 inch, includes parts 45, 46, 47
237872	KIT, ballstop, 1 inch, includes parts 45, 46, 47
24R060	KIT, ballstop, 1-1/4 inch, includes parts 45, 46, 47
24R061	KIT, ballstop, 1-1/2 inch, includes parts 45, 46, 47
24R062	KIT, power spring, D, includes 10, 12, 13, 14, 32, 48
24R063	KIT, power spring, C, includes 10, 12, 13, 14, 32, 48
24R064	KIT, power spring, B, includes 10, 12, 13, 14, 32, 48
24R065	KIT, power spring, A, includes 10, 12, 13, 14, 32, 48
24R066	KIT, latch, includes 16, 18
24R067	KIT, inlet, 1 inch, npt, general, includes 6, 29, 33
24R068	KIT, inlet, 1-1/2 inch, npt, general, includes 6, 29, 33
24R674	KIT, inlet, 1 inch, BSPP, general, includes 6, 29, 33

Part No.	Description
24R675	KIT, inlet, 1 inch, BSPT, general, includes 6, 29, 33
24R677	KIT, inlet, 1-1/2 inch, general, BSPP, includes 6, 29, 33
24R678	KIT, inlet, 1-1/2 inch, BSPT, general, includes 6, 29, 33
129137	KIT, inlet, 1 inch, npt, antifreeze, includes 6, 29, 33
24R070	KIT, bearing, low pressure bearing, includes 29, 41, 49
24R071	KIT, bearing, medium pressure, includes 4, 5, 35, 41, 42, 50, 51
24R072	KIT, roller guide, XD40, includes 9, 23, 24, 25, 26, 27, 28, 39, 40, 43
24R073	KIT, roller guide, XD40, includes 23, 24, 25, 26, 27, 39, 40
24R074	KIT, roller guide, XD50, includes 9, 23, 24, 25, 26, 27, 28, 39, 40, 43
24R075	KIT, roller guide, XD50, includes 23, 24, 25, 26, 27, 39, 40
24R076	KIT, support arm, XD40
24R077	KIT, support arm, XD50
24R336	KIT, Low Pressure Shaft, includes parts 3, 4, 32, 48
24R337	KIT, Medium Pressures shaft, includes parts 3, 4, 32, 48
24R339	KIT, bearing, spring side, includes 7, 8, 12, 14, 15, 32, 48
24R111	KIT, inlet hose, 1 inch, air/water and oil, includes 1 inch swivel fitting and 1 inch x 28 inch coupled hose
24R112	KIT, inlet hose, 1 inch, waste oil evacuation, includes 1 inch swivel fitting and 1 inch x 28 inch coupled hose
24R115	KIT, inlet hose, 1 inch, fuel, includes 1 inch swivel fitting and 1 inch x 28 inch coupled hose
24R117	KIT, inlet hose, 1.5 inch, fuel, includes 1 inch swivel fitting and 1.5 inch x 28 inch coupled hose
24R953	KIT, shaft, low pressure, includes 9, 11, 12, 14, 32, 48
24R954	KIT, shaft, medium pressure, includes 9, 11, 12, 14, 32, 48
237932	KIT, mounting, overhead, fits standard I-beams with flanges up to 7 in. (178 mm)

Technical Data

XD40, XD50 Hose Reels		
	US	Metric
Maximum fluid working pressure	See model table, page 3-7	
Operating Temperature		
Bare Reels	-40°F to 180°F	-40°C to 82°C
Air / Water Reels	-40°F to 180°F	-40°C to 82°C
Waste Oil Evacuation Reels	-40°F to 180°F	-40°C to 82°C
1/2-inch and 3/4-inch Oil Reels	-40°F to 180°F	-40°C to 82°C
1-inch Oil Reels	-20°F to 180°F	-29°C to 82°C
Diesel Fuel Reels	-40°F to 140°F	-40°C to 60°C
Antifreeze Reels	-40°F to 180°F	-40°C to 82°C
Inlet/Outlet Sizes		
XD4010 / XD5010 Inlet size	1 npt(f)	
XD4010 / XD5010 Outlet size	1 npt(f)	
XD5015 Inlet size	1-1/2 in. npt(f)	
XD5015 Outlet size	1-1/2 npt(f)	
Materials of construction		
XD40 Wetted materials	carbon steel, nickel plated cast iron, buna-n rubber, FKM UHMWPE	
XD50 Wetted materials	carbon steel, nickel plated cast iron, buna-n rubber, FKM UHMWPE	
Noise (dBa)		
Sound Pressure Level†	77.6 dB(a)	
Sound Power Level‡	86.8 dB(a)	
Weight (Bare Reels)		
XD4010 DLP models	116 lb.	52.6 kg
XD4010 CLP models	125 lb.	56.7 kg
XD4010 CMP models	125 lb.	56.7 kg
XD4010 BMP models	134 lb.	60.8 kg
XD4010 AMP models	152 lb.	68.9 kg
XD5010 ALP models	162 lb.	73.4 kg
XD5010 BLP models	145 lb.	65.7 kg
XD5010 AMP models	162 lb.	73.4 kg
XD5015 BLP models	146 lb.	66.2 kg
XD5015 ALP models	164 lb.	74.4 kg
Maximum Recommended Mounting Height		
XD40 models	15 feet	4.6 meters
XD50 and XD4010 CMP models	8 feet	2.4 meters
Notes		
† Calculated at a distance of 1 meter from measurements taken per ISO 9614-2 @ an assumed retraction/extension rate of 20 spool revolutions per minute.		
‡ Measured per ISO 9614-2 @ an assumed retraction/extension rate of 20 spool revolutions per minute.		

Dimensions

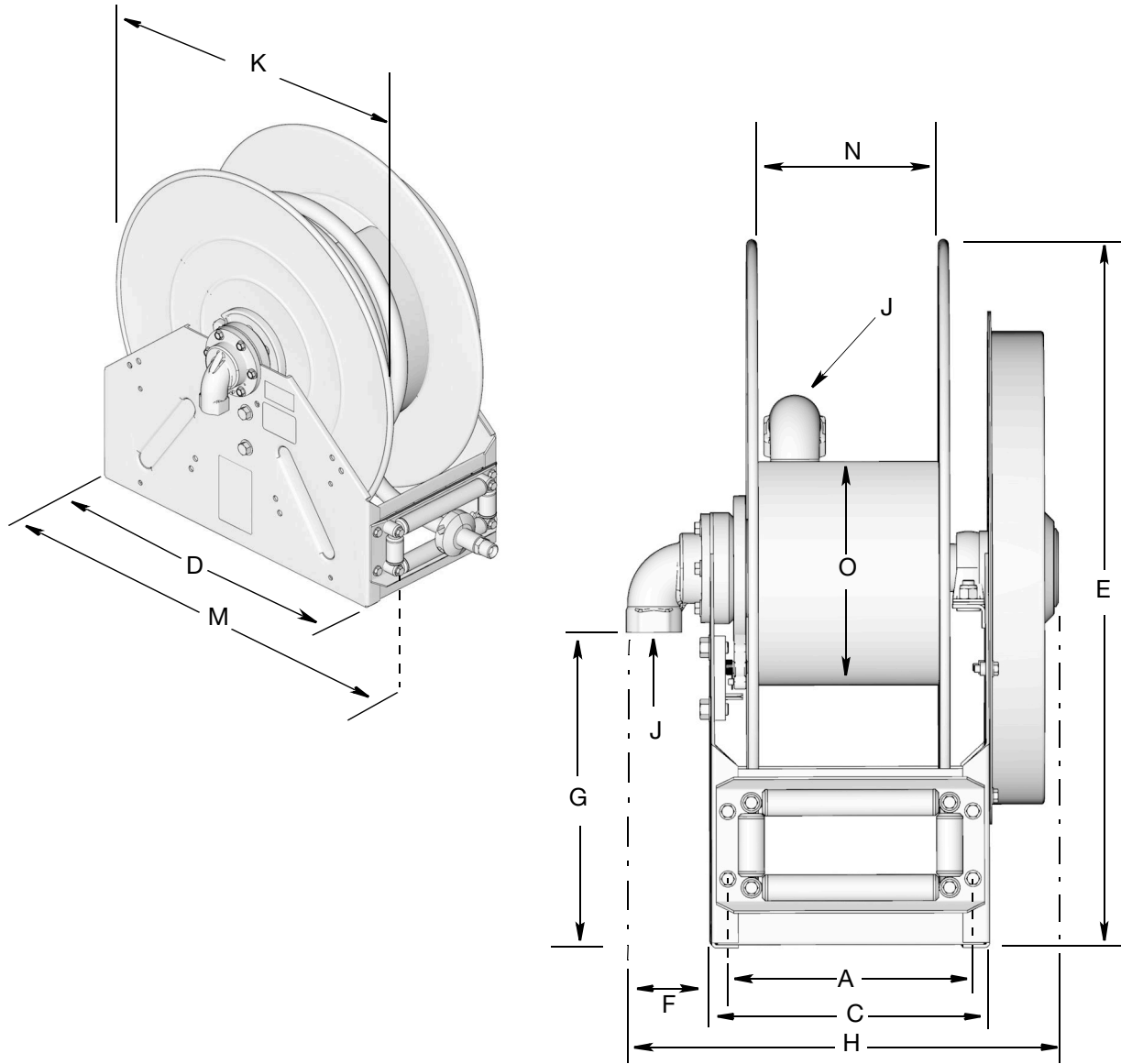

All dimensions shown in inches

Model	Spring	A	C	D	E	F	G	H	J	K	M	N	O
XD4010	C/D	10.45	11.83	24.0	26.13	2.82	10.91	16.54	1.0 npt	25.0	26.4	7.8	15.5
XD4010	A/B			28.5	30.13			17.47					
XD5010	A/B			28.5	30.13			17.47	28.0	29.4			
XD5015	A/B			3.59	18.24	1-1/2 npt		28.0	29.4				

All dimensions shown in mms

Model	Spring	A	C	D	E	F	G	H	J	K	M	N	O
XD4010	C/D	265.4	300	610	664	72	277	420	1.0 npt	635	671	198	394
XD4010	A/B			724	765			444					
XD5010	A/B			724	765			444	711.2	747			
XD5015	A/B			91	463	1-1/2 npt		711.2	747				

Mounting Hole Pattern

XD40 Reels

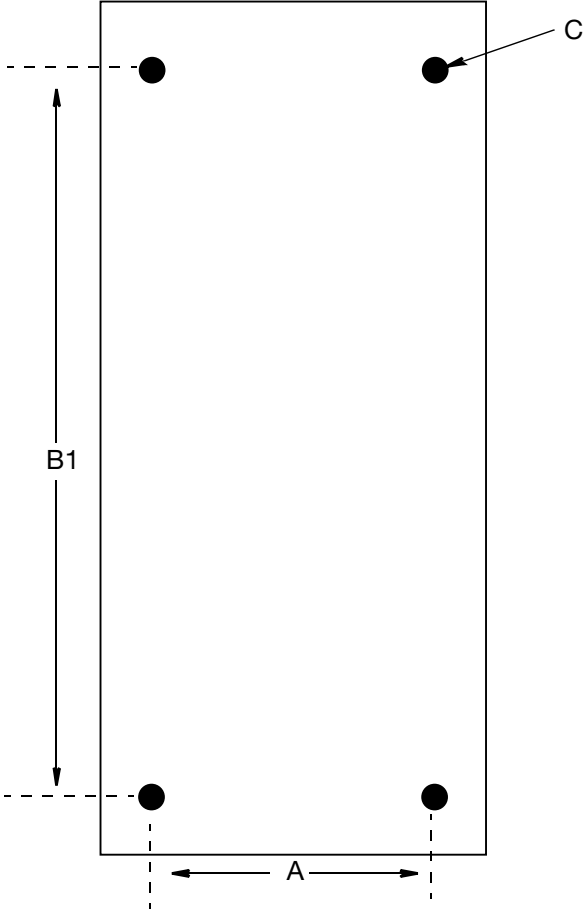

XD50 Reels

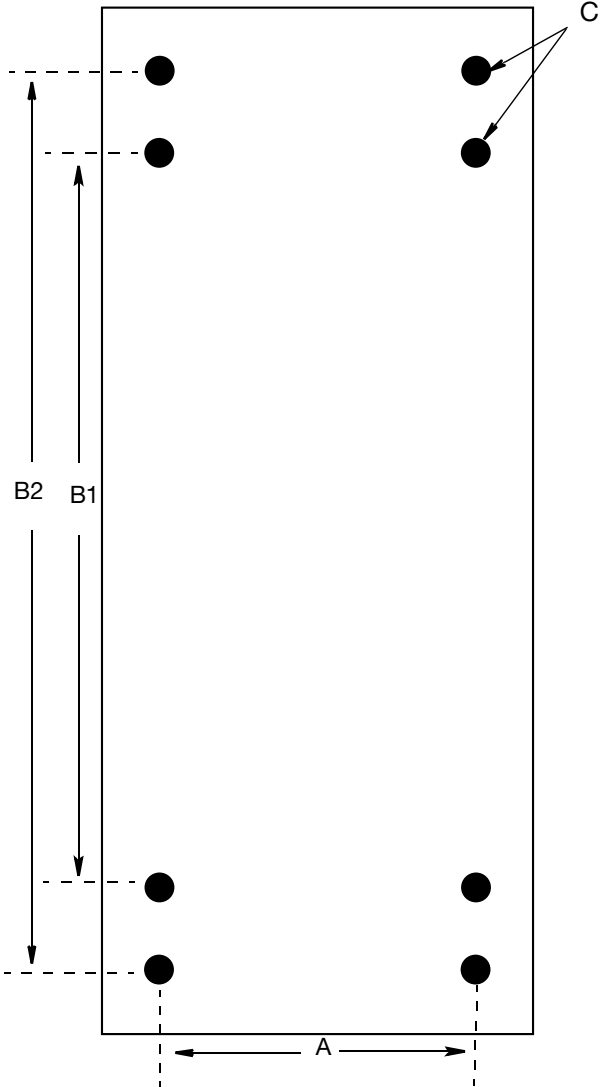

All dimensions shown in inches

Model	Spring	A	B1	B2	
XD4010	C/D	10.45	22.25	n/a	Ø 0.437
XD4010	A/B				
XD5010	A/B			26.73	
XD5015	A/B				

All dimensions shown in mms

Model	Spring	A	B1	B2	C
XD4010	C/D	265.4	565.2	n/a	Ø 11
XD4010	A/B				
XD5010	A/B			678.9	
XD5015	A/B				

Table 1: Spring Tension Pre-turns

Air / Water / Antifreeze Models

Model	Hose Inside Diameter	Hose Length	Number of Pre-Turns From Relaxed State
XD40	0.5 inch	100 feet	24
XD40	0.75 inch	75 feet	25
XD40	0.75 inch	100 feet	25
XD40	1 inch	50 feet	24
XD50	1 inch	75 feet	22
XD50	1 inch	100 feet	26

Oil Models

Model	Hose Inside Diameter	Hose Length	Number of Pre-Turns From Relaxed State
XD40	0.5 inch	100 feet	25
XD4010B	0.75 inch	75 feet	25
XD4010C	0.75 inch	75 feet	27
XD40	0.75 inch	100 feet	30
XD4010B	1 inch	50 feet	25
XD4010C	1 inch	50 feet	27
XD50	1 inch	75 feet	30

Waste Oil Evacuation Models

Model	Hose Inside Diameter	Hose Length	Number of Pre-Turns From Relaxed State
XD40	1 inch	50 feet	26
XD50	1.25 inch	35 feet	17
XD50	1.25 inch	50 feet	20

Fuel Models

Model	Hose Inside Diameter	Hose Length	Number of Pre-Turns From Relaxed State
XD40	1 inch	50 feet	26
XD50	1 inch	75 feet	21
XD50	1 inch	100 feet	26
XD50	1.25 inch	35 feet	18
XD50	1.25 inch	50 feet	21
XD50	1.5 inch	50 feet	22

Graco 7-Year Hose Reel Warranty

Graco warrants all equipment referenced in this document which is manufactured by Graco and bearing its name to be free from defects in material and workmanship on the date of sale to the original purchaser for use. With the exception of any special, extended, or limited warranty published by Graco, Graco will, for a period from the date of sale as defined in the table below, repair or replace equipment covered by this warranty and determined by Graco to be defective. This warranty applies only when the equipment is installed, operated and maintained in accordance with Graco's written recommendations.

Graco 7-Year Hose Reel Extended Warranty	
Component	Warranty Period
Structural Components	7 years
Power Spring	3 years
Wear Parts - including but not limited to hose, seals, swivel seats and roller guides	1 year
Bare reels - all components	1 year

This warranty does not cover, and Graco shall not be liable for general wear and tear, or any malfunction, damage or wear caused by faulty installation, misapplication, abrasion, corrosion, inadequate or improper maintenance, negligence, accident, tampering, or substitution of non-Graco component parts. Nor shall Graco be liable for malfunction, damage or wear caused by the incompatibility of Graco equipment with structures, accessories, equipment or materials not supplied by Graco, or the improper design, manufacture, installation, operation or maintenance of structures, accessories, equipment or materials not supplied by Graco.

This warranty is conditioned upon the prepaid return of the equipment claimed to be defective to an authorized Graco distributor for verification of the claimed defect. If the claimed defect is verified, Graco will repair or replace free of charge any defective parts. The equipment will be returned to the original purchaser transportation prepaid. If inspection of the equipment does not disclose any defect in material or workmanship, repairs will be made at a reasonable charge, which charges may include the costs of parts, labor, and transportation.

THIS WARRANTY IS EXCLUSIVE, AND IS IN LIEU OF ANY OTHER WARRANTIES, EXPRESS OR IMPLIED, INCLUDING BUT NOT LIMITED TO WARRANTY OF MERCHANTABILITY OR WARRANTY OF FITNESS FOR A PARTICULAR PURPOSE.

Graco's sole obligation and buyer's sole remedy for any breach of warranty shall be as set forth above. The buyer agrees that no other remedy (including, but not limited to, incidental or consequential damages for lost profits, lost sales, injury to person or property, or any other incidental or consequential loss) shall be available. Any action for breach of warranty must be brought within one (1) year past the warranty period or two (2) years for all other parts.

GRACO MAKES NO WARRANTY, AND DISCLAIMS ALL IMPLIED WARRANTIES OF MERCHANTABILITY AND FITNESS FOR A PARTICULAR PURPOSE, IN CONNECTION WITH ACCESSORIES, EQUIPMENT, MATERIALS OR COMPONENTS SOLD BUT NOT MANUFACTURED BY GRACO. These items sold, but not manufactured by Graco (such as electric motors, switches, hose, etc.), are subject to the warranty, if any, of their manufacturer. Graco will provide purchaser with reasonable assistance in making any claim for breach of these warranties.

In no event will Graco be liable for indirect, incidental, special or consequential damages resulting from Graco supplying equipment hereunder, or the furnishing, performance, or use of any products or other goods sold hereto, whether due to a breach of contract, breach of warranty, the negligence of Graco, or otherwise.

FOR GRACO CANADA CUSTOMERS

The Parties acknowledge that they have required that the present document, as well as all documents, notices and legal proceedings entered into, given or instituted pursuant hereto or relating directly or indirectly hereto, be drawn up in English. Les parties reconnaissent avoir convenu que la rédaction du présente document sera en Anglais, ainsi que tous documents, avis et procédures judiciaires exécutés, donnés ou intentés, à la suite de ou en rapport, directement ou indirectement, avec les procédures concernées.

Graco Information

For the latest information about Graco products, visit www.graco.com.

TO PLACE AN ORDER, contact your Graco distributor or call to identify the nearest distributor.

Phone: 612-623-6928 or **Toll Free:** 1-800-533-9655, **Fax:** 612-378-3590

*All written and visual data contained in this document reflects the latest product information available at the time of publication.
Graco reserves the right to make changes at any time without notice.*

For patent information, see www.graco.com/patents.

Original instructions. This manual contains English. MM 3A2990

Graco Headquarters: Minneapolis
International Offices: Belgium, China, Japan, Korea

GRACO INC. AND SUBSIDIARIES • P.O. BOX 1441 • MINNEAPOLIS MN 55440-1441 • USA

Copyright 2013, Graco Inc. All Graco manufacturing locations are registered to ISO 9001.

www.graco.com

Revision L, May 2022